



# MX1500

## Size: AA (LR6)

### Alkaline-Manganese Dioxide Battery

Zn/MnO<sub>2</sub>

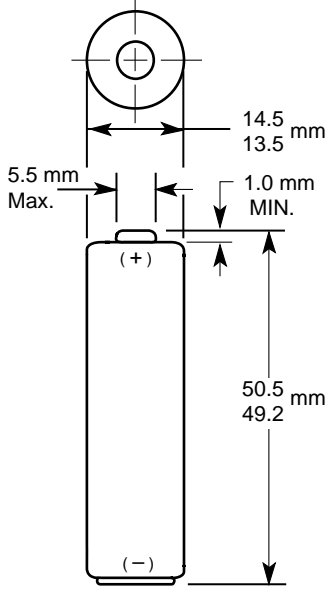

Dimensions shown are IEC/ANSI standards

<b>Nominal Voltage:</b>	1.5 V
<b>Nominal Internal Impedance:</b>	81 m-ohm @ 1kHz
<b>Average Weight:</b>	24.3 gm (0.86 oz.)
<b>Volume:</b>	8.4 cm <sup>3</sup> (0.51 in. <sup>3</sup> )
<b>Terminals:</b>	Flat
<b>Operating Temperature Range:</b>	-20°C to 54°C (-4°F to 130°F)
<b>NEDA/ANSI:</b>	15A
<b>IEC:</b>	LR6

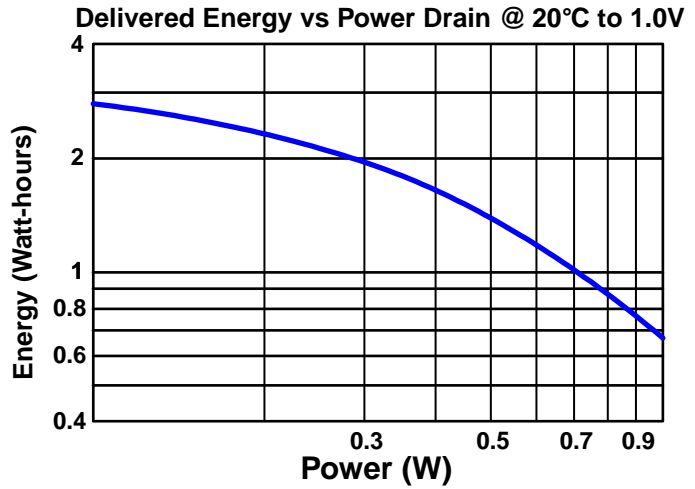

### Duracell Ultra AA vs. Standard AA Alkaline

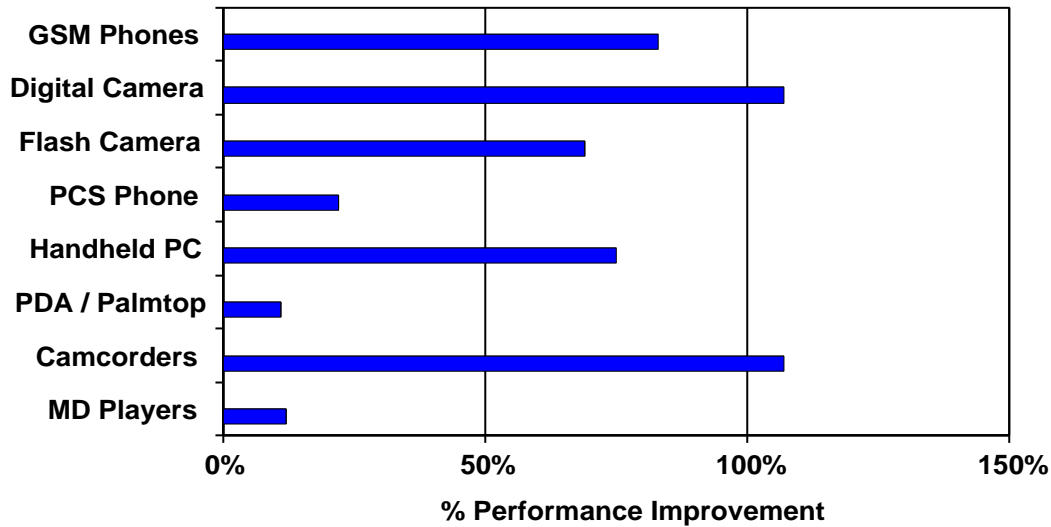

\* Delivered capacity is dependent on the applied load, operating temperature and cut-off voltage. Please refer to the charts and discharge data shown for examples of the energy / service life that the battery will provide for various load conditions.



# MX1500

Size: AA (LR6)  
Alkaline-Manganese Dioxide Battery

Zn/MnO<sub>2</sub>

## Discharge Characteristics at Various Power Drains

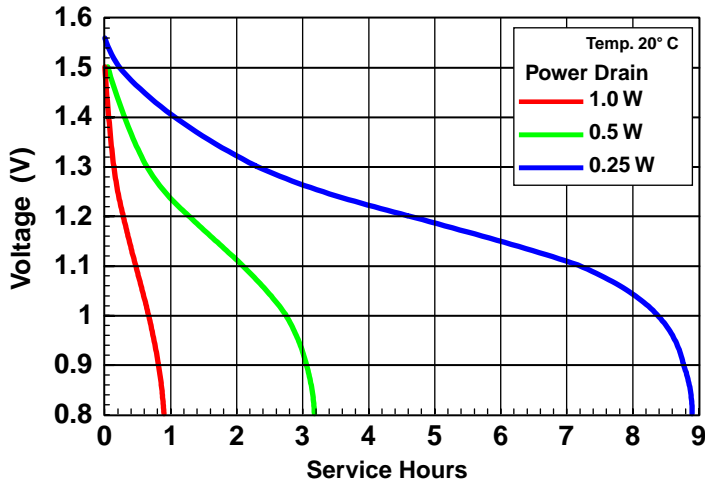

## Service Hours vs Power Drain

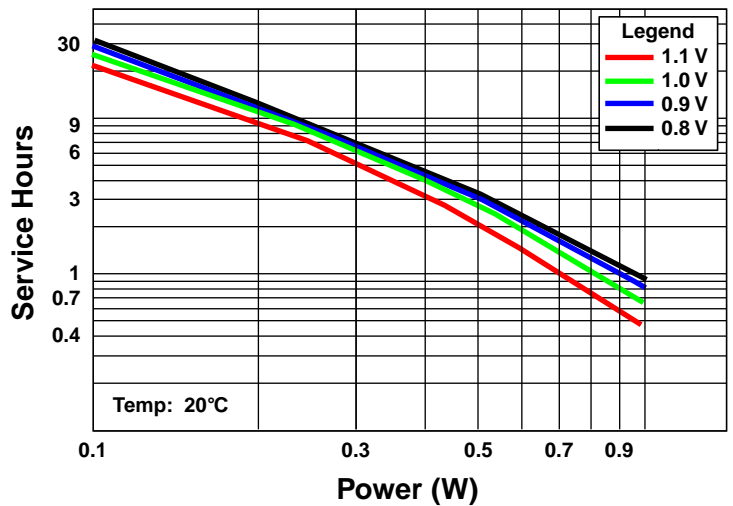

## Delivered Energy vs Power Drain At Various Cutoff Voltages

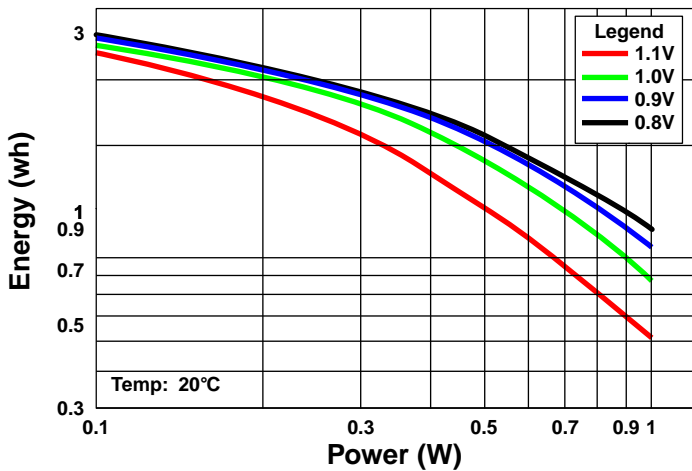

## Delivered Capacity vs Power Drain At Various Cut-off Voltages

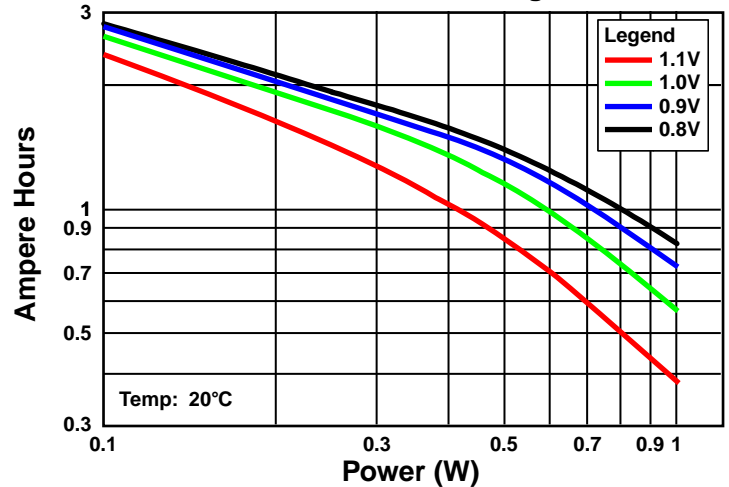

**DURACELL**<sup>®</sup>  
BATTERIES

Berkshire Corporate Park  
Bethel, CT 06801 U.S.A.  
Telephone: Toll-free 1-800-431-2656  
Facsimile: 203-796-4209  
Internet: www.duracell.com

\* Delivered capacity is dependent on the applied load, operating temperature and cut-off voltage. Please refer to the charts and discharge data shown for examples of the energy / service life that the battery will provide for various load conditions.